

# AUDIO

*a key element in any good design*



*“If you’re not using audio in your exhibits and displays, perhaps you should think again. Experts agree that audio plays a critical role in learning about the world around us.”*

## **The Power of Audio**

Imagine children in a classroom full of pictures and artifacts, but no verbal explanation to go along with them. Without the teacher’s explanations, students learn nothing and will quickly become bored. How about a T.V. commercial with the sound turned off?- the images alone are nice, but don’t contain much useful information. Turn the sound *on* and you get an easy to understand message! When it comes to getting information across, the visual helps to augment the audio, but the *real* work is done by the *audio*.

What about the written word? It appears that the *written* word is just a way to record the *spoken* word. As you read these sentences, your mind is decoding sequences of letters into recognizable words. They’re sent to the aural processing centers of the brain to be further decoded into aural equivalents before they are truly understood. It’s no wonder we must all learn how to talk before we can learn to read, and why young readers move their lips when reading. Audio also conveys emotional content that’s tough to communicate by any other means.

## **Sound Effects: a Living Background**

In a display or exhibit setting, simple sound effects or background audio can do wonders to provide the viewer with a real ‘sense’ of what it is they are looking at. Imagine a Blacksmith’s shop at the turn of the century: can you hear the clink-clink-clinking of a hammer against an iron anvil and the whinny of a horse in the background? How about a WWII battle scene, or an ancient forest exhibit? Without sound to provide a richness of context, exhibits can be lifeless and flat.

*Audio recorders from Stop and Listen:  
...bring your exhibits to life.*

**[www.stopliten.com](http://www.stopliten.com)**

Stop and Listen Inc, 7515 Flint Road S.E., Calgary, Alberta, Canada T2H 1G3  
1-800-387-2365 voice 403 276-5905 fax 403 230-9243 e-mail [info@stopliten.com](mailto:info@stopliten.com)



# Digital Technology

@stoplisten.com

## About the Company

At Stop and Listen Inc we design and manufacture leading-edge digital and analog audio products for the interpretive and exhibits industries. We pride ourselves in our unparalleled product quality and customer support. Through the years we've focused our research and design efforts towards products that give the exhibit designer greater control over the audio messages that they provide to the public. A quick glance at our customer list will show how far this philosophy has taken us.

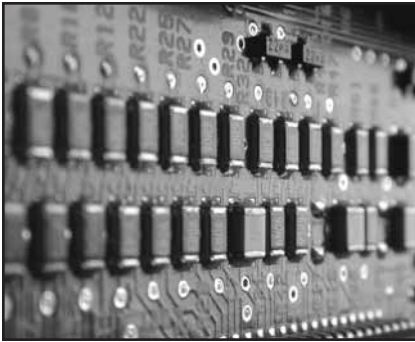

## Why Solid-State Digital?

Solid-state construction means there are no moving parts or tapes to wear out, even after millions of plays. Audio Recorders can handle the toughest conditions, from solar-powered systems in the wind-swept mountains of the Yukon to salt air, humidity and blowing sand in the Gulf of Mexico. Messages play back the same way every time, with no loss in fidelity.

## What is On-site Recordable?

On all of our Audio Recorders messages can be easily change on location with no special training or equipment required. This means that audio can be moved around from exhibit to exhibit, and you're no longer 'stuck' in an 'audio rut'. As your needs (or the seasons) change, simply press RECORD on the Digital Audio Recorder, play the new message from the original tape or CD, and your new message is 'locked-in' to memory until you want to record something else.

Audio information is digitally encoded using built-in circuitry, and stored in state-of-the-art Flash memory chips. On playback, the digital information is retrieved from memory and re-converted back to it's original analog form, while maintaining the clarity you've come to expect from digital.

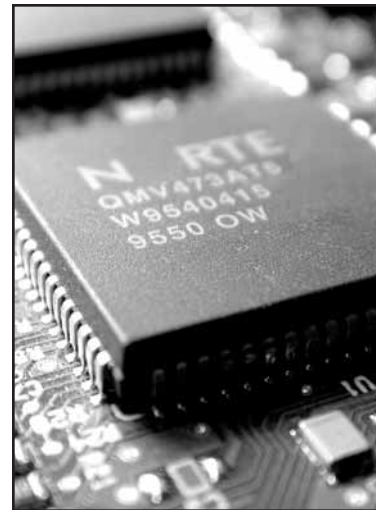

---

*We hope you'll find the enclosed information helpful in putting audio to work. Give us a call with any questions you might have - whether it's groundwork for a new exhibit or adding a little zip and zing to one that's starting to show it's age.*

[www.stoplisten.com](http://www.stoplisten.com)

Stop and Listen Inc, 7515 Flint Road S.E., Calgary, Alberta, Canada T2H 1G3  
1-800-387-2365 voice 403 276-5905 fax 403 230-9243 e-mail [info@stoplisten.com](mailto:info@stoplisten.com)



# Digital Audio Recorder Model DAR-050



## Features

- Single Message
- Up to 1 minute 50 seconds
- On-Site Recordable / Re-recordable
- Nonvolatile FLASH Memory
- Incredible Fidelity
- 6 Watt Speaker Output
- Built-In PowerSaver Features
- 5 Year 'Gold Seal' Warranty

## Applications

- Exhibits / Kiosks / Dioramas
- Interactive Multimedia
- Interpretive Tours / Announcements
- Multiple Languages
- Background Ambience / Soundscapes

The **Digital Audio Recorder Model DAR-050** from Stop and Listen digitally records, stores, and plays back one message of up to 110 seconds duration. The message can be changed in moments with no special training or equipment required - just hook up a source, press record, and your message is loaded into maintenance-free digital memory. You can record from CD's, tape decks, from your PC: almost anything with an audio output.

Playback is started with any contact closure, whether it's a visitor push-button, motion sensor, or almost any other triggering device. Messages can also be set for continuous play mode, making the DAR-050 an ideal choice for background music and ambient soundscapes. It's compact size fits anywhere, it's solar compatible and suitable for both indoors and out.

The DAR-050 is packed with all the right features to make your exhibit a success, including our 5 year 'Gold Seal' warranty. Every unit comes fully loaded with memory, built-in amplifier, a 12 volt power supply and a full set of audio patch cords. Just add a speaker and a button and it's ready to roll!

Available options include: output speakers, pushbuttons, motion sensors, Podium, handsets, etc.

**MAKING AUDIO EASY...**

**STOP & LISTEN**

DETAILED SPECIFICATIONS ON REVERSE

# Digital Audio Recorder Model DAR-050

## Technical Specifications

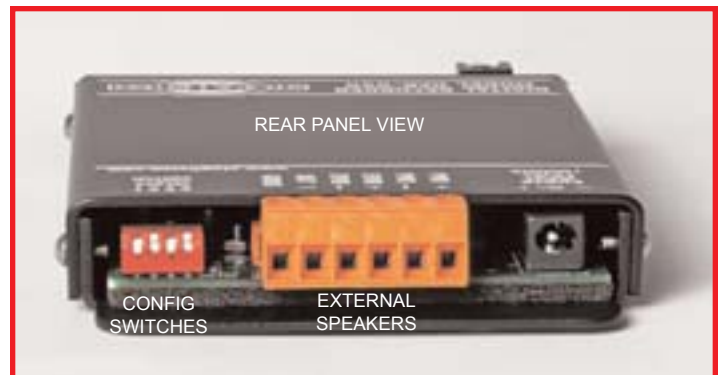

## Specifications: Digital Audio Recorder DAR-050

Max Recording Time	1 minute 50 seconds (110 seconds)
Digital Sampling Rate	39.06 kHz (kilohertz), fixed
Digital Compression	None, not required
Frequency Response	50-14.5kHz (@nom input, +/-3dB) fixed
Message Capability	single message
Audio Inputs -Line Level	230mV p-p (-20dBm) sensitivity, 10k impedance, adjustable
Audio Processing	On-board variable slope analog compression/expansion
Audio/ Anti-Alias Filters	8th order Butterworth-type, Burton Implementation
Dynamic Range	>70+ dB
Audio Output -SPKR	6 watt nom / 2.2 watt true RMS speaker level, bridged, adjustable volume, user-configurable to 200mV Line Level output
Controls	Input Volume, Speaker Volume, local start, local record
Memory Type	32mbit / 4MB non-volatile NAND Flash EEPROM
Memory Backup	NOT REQUIRED, non-volatile
A/D Conversion	Companded 8 Bit Linear, real time streaming
Indicators	VU Level on Rec/PB, PowerSaver Status, Play Status, Record Status
Start Input	Momentary dry contact closure for single play, sustained for continuous play Input is configurable for interruptible/non-interruptible mode, or N.C. contacts
PowerSaver Capability	selectable on/off, proprietary auto-standby mode for remote power systems
Power Consumption	60mA @ 12 VDC (typical, average), 290 microamps standby in PowerSaver mode
Power Supply (supplied)	12 VDC output nominal @ 800 mA, 120 VAC source
Approvals	Class II Device, CSA, UL, FCC CLASS A Compliant
Construction Standard	Industrial/Commercial, carbon steel enclosure, polyester finish
Operating Temp/Humid.	-20°F to +130°F (-30°C to +55°C), non-condensing
Dimensions, Weight	3.5"w x 6.0"d x 0.75"h, 1.8 lbs (89mm x 152mm x 19mm, 0.7 kg)
Warranty	5 year 'Gold Seal' manufacturer direct

*Includes 12VDC Power Supply, Set of Audio Patch Cords, Detailed Operating Instructions*

PRINTED IN CANADA ON RECYCLABLE PAPER

**Stop and Listen**  
**[www.stoplisten.com](http://www.stoplisten.com)**  
**1-800-387-2365**

DISTRIBUTED BY:

**STOP & LISTEN**



# Digital Audio Recorder Model DAR-100

## Features

- Single Message
- Up to 11 Minutes
- On-Site Recordable / Re-recordable
- Nonvolatile FLASH Memory
- Incredible Fidelity
- Dual Speaker Output with Line Out
- Built-In PowerSaver Features
- 5 Year 'Gold Seal' Warranty

## Applications

- Exhibits / Kiosks / Dioramas
- Interactive Multimedia
- Interpretive Tours / Announcements
- Multiple Languages
- Background Ambience / Soundscapes



The **Digital Audio Recorder Model DAR-100** from Stop and Listen digitally records, stores, and plays back one message of up to 11 minutes duration. The message can be changed in moments with no special training or equipment required - just hook up a source, press record, and your message is loaded into maintenance-free digital memory. You can record from CD's, tape decks, from your PC, or straight from a microphone.

Playback can be started with any contact closure, whether it's a visitor push-button, motion sensor, or almost any other triggering device. Messages can also be set for continuous play mode, making the DAR-100 an ideal choice for background music and ambient soundscapes. It's compact size fits anywhere, it's solar compatible and suitable for both indoors and out.

The DAR-100 is packed with all the right features to make your exhibit a success, including our 5 year 'Gold Seal' warranty. Every unit comes fully loaded with memory, built-in amplifiers, a 12 volt power supply and a full set of audio patch cords. Just add a speaker and a button and it's ready to roll!

Available options include: output speakers, pushbuttons, motion sensors, Podium, handsets, etc.

**MAKING AUDIO EASY...**

**STOP & LISTEN**

DETAILED SPECIFICATIONS ON REVERSE

# Digital Audio Recorder Model DAR-100

## Technical Specifications

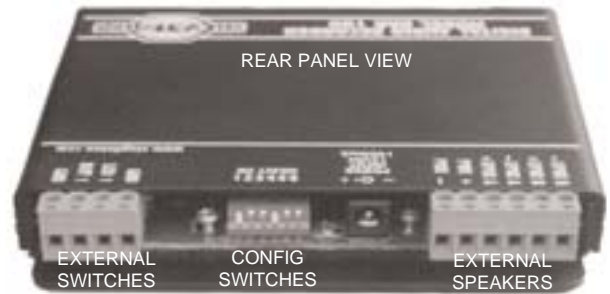
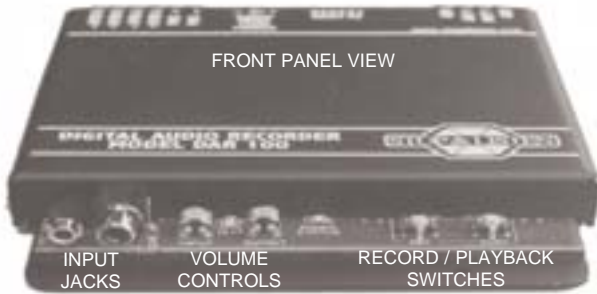

### Specifications: Digital Audio Recorder DAR-100

Digital Sampling Rate is user selectable and effects Frequency Response and Max Recording Time as outlined.

Max. Record Time (min:sec)	3:40	5:30	7:20	11:00
Freq. Resp. (@nom input, +/-3dB)	50-14.5kHz	50-6.8kHz	50-6.8kHz	50-6.8kHz
Digital Compression	none	none	none	2:1 Adaptive
Digital Sampling Rate	39.06kHz	26.04kHz	19.53kHz	26.04kHz

Message Capability	single message only
Audio Inputs -Line Level	230mV p-p (-20dBm) sensitivity, 10k impedance, adjustable
-Mic Level	5mV p-p (-53dBm) sensitivity, unbalanced, 30 dB gain, 3.5mm jack
Audio Processing	On-board variable slope compression/expansion
Audio/ Anti-Alias Filters	8th order Butterworth-type
Dynamic Range	70+dB
Audio Output -Output A	6 watt nom / 2.2 watt true RMS speaker level, bridged, adjustable
-Output B	6 watt as above, user configurable to 200mV Line Level
LED Output	5 volt 5mA sourcing, active on playback
Memory Type	64mbit / 8MB non-volatile NAND Flash EEPROM
Memory Backup	NOT REQUIRED, non-volatile
A/D Conversion	Companded 8 Bit Linear, real time streaming
Indicators	VU Level on Rec/PB, PowerSaver Status, Play Status, Record Status
Start Input	Momentary dry contact closure for single play, sustained for continuous play
	Inputs are user configurable for interruptible/non-interruptible modes
PowerSaver Capability	selectable on/off, proprietary auto-standby mode for remote power systems
Power Consumption	60mA @ 12 VDC (typical, average), 140 microamps standby in PowerSaver mode
Power Supply (supplied)	12 VDC output nominal @ 1000 mA, 120 VAC source
Approvals	Class II Device, CSA, UL, FCC CLASS A Compliant
Construction Standard	Industrial/Commercial, carbon steel enclosure, polyester finish
Operating Temp/Humid.	-20°F to +130°F (-30°C to +55°C), non-condensing
Dimensions, Weight	5.0"w x 6.0"d x 0.75"h, 2.0 lbs (130mm x 152mm x 19mm, 0.9 kg)
Warranty	5 year 'Gold Seal' manufacturer direct

*Includes 12VDC Power Supply, Set of Audio Patch Cords, Detailed Operating Instructions*

PRINTED IN CANADA ON RECYCLABLE PAPER

**Stop and Listen**  
[www.stoplisten.com](http://www.stoplisten.com)  
**1-800-387-2365**

DISTRIBUTED BY:

**STOP & LISTEN**

# Digital Audio Recorder Model DAR-200

## Features

- Dual or Single Message
- Up to 22 Minutes
- On-Site Recordable / Re-recordable
- Nonvolatile FLASH Memory
- Incredible Fidelity
- Dual Speaker Output with Line Out
- Built-In PowerSaver Features
- 5 Year 'Gold Seal' Warranty

## Applications

- Exhibits / Kiosks / Dioramas
- Interactive Multimedia
- Interpretive Tours / Announcements
- Multiple Languages
- Background Ambience / Soundscapes



The **Digital Audio Recorder Model DAR-200** from Stop and Listen digitally records, stores, and plays back one or two messages of up to 22 minutes combined duration. Messages can be changed in moments with no special training or equipment required - just hook up a source, press record, and your message is loaded into maintenance-free digital memory. You can record from CD's, tape decks, from your PC, or straight from a microphone.

Playback can be started with any contact closure, whether it's a visitor push-button, motion sensor, or almost any other triggering device. Messages can also be set for continuous play mode, making the DAR-200 an ideal choice for background music and ambient soundscapes. It's compact size fits anywhere, it's solar compatible and suitable for both indoors and out.

The DAR-200 is packed with all the right features to make your exhibit a success, including our 5 year 'Gold Seal' warranty. Every unit comes fully loaded with memory, built-in amplifiers, a 12 volt power supply and a full set of audio patch cords. Just add a speaker and a button and it's ready to roll!

Available options include: output speakers, pushbuttons, motion sensors, Podium, handsets, etc.

**MAKING AUDIO EASY...**

**STOP & LISTEN**

DETAILED SPECIFICATIONS ON REVERSE

# Digital Audio Recorder Model DAR-200

## Technical Specifications

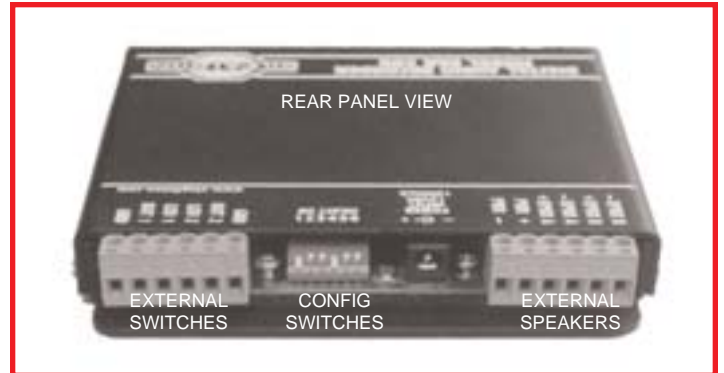
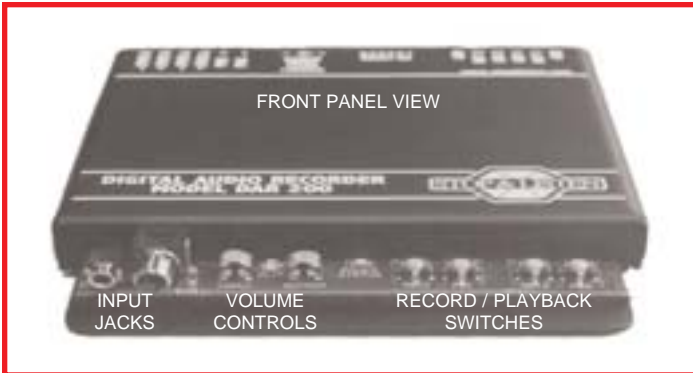

### Specifications: Digital Audio Recorder DAR-200

Digital Sampling Rate is user selectable and effects Frequency Response and Max Recording Time as outlined.

Max. Record Time (1+2 combined, min:sec)	7:20	11:00	14:40	22:00
Freq. Resp. (@nom input, +/-3dB)	50-14.5kHz	50-6.8kHz	50-6.8kHz	50-6.8kHz
Digital Compression	none	none	none	2:1 Adaptive
Digital Sampling Rate	39.06kHz	26.04kHz	19.53kHz	26.04kHz

Message Capability	1 or 2 messages, selectable, accessed 1 at a time
Audio Inputs -Line Level	230mV p-p (-20dBm) sensitivity, 10k impedance, adjustable
-Mic Level	5mV p-p (-53dBm) sensitivity, unbalanced, 30 dB gain, 3.5mm jack
Audio Processing	On-board variable slope compression/expansion
Audio/ Anti-Alias Filters	8th Order Butterworth-type
Dynamic Range	70+dB
Audio Output -Output A	6 watt nom / 2.2 watt true RMS speaker level, bridged, adjustable
-Output B	6 watt as above, user configurable to 200mV Line Level
LED Outputs (2)	5 volt 5mA sourcing, active on playback, one per message
Memory Type	128mbit / 16MB non-volatile NAND Flash EEPROM
Memory Backup	NOT REQUIRED, non-volatile
A/D Conversion	Companded 8 Bit Linear, real time streaming
Indicators	VU Level on Rec/PB, PowerSaver Status, Play Status, Record Status
Start Inputs - S1, S2	Momentary dry contact closure for single play, sustained for continuous play Inputs are user configurable for interruptible/non-interruptible modes
PowerSaver Capability	selectable on/off, proprietary auto-standby mode for remote power systems
Power Consumption	60mA @ 12 VDC (typical, average), 140 microamps standby in PowerSaver mode
Power Supply (supplied)	12 VDC output nominal @ 1000 mA, 120 VAC source
Approvals	Class II Device, CSA, UL, FCC CLASS A Compliant
Construction Standard	Industrial/Commercial, carbon steel enclosure, polyester finish
Operating Temp/Humid.	-20°F to +130°F (-30°C to +55°C), non-condensing
Dimensions, Weight	5.0"w x 6.0"d x 0.75"h, 2.0 lbs (130mm x 152mm x 19mm, 0.9 kg)
Warranty	5 year 'Gold Seal' manufacturer direct

*Includes 12VDC Power Supply, Set of Audio Patch Cords, Detailed Operating Instructions*

**Stop and Listen**  
**www.stoplisten.com**  
**1-800-387-2365**

DISTRIBUTED BY:

**STOP & LISTEN**



# Digital Audio Recorder Model DAR-800

## Features

- 1 to 8 Individual Messages
- Up to 44 Minutes Combined
- Play Selected / Play Next / Play All
- On-Site Recordable / Re-recordable
- Incredible Fidelity
- Dual Speaker Output with Line Out
- Built-In PowerSaver Features
- Dedicated LED Outputs
- 5 Year Warranty

## Applications

- Multiple Languages
- Bird Songs / Bug Sounds
- Q&A - Question and Answer
- Announcements
- Sound Effects



The **Digital Audio Recorder Model DAR-800** from Stop and Listen records up to 8 different messages of up to 44 minutes combined duration. It can be changed in moments with no special training or equipment required - just hook up a source, press record, and messages are loaded into maintenance-free digital memory. You can record from CD's, tape decks, from your PC, or straight from a microphone.

Playback can be started with any contact closure, whether it's a visitor push-button, motion sensor, or almost any other triggering device. 3 different playback modes provide maximum flexibility: *Play Selected* plays any message once, *Play Next* plays the next message in sequence, or play everything once by selecting *Play All*.

The DAR-800 has all the right features to make your exhibit a success, including a full 5 year warranty. It's compact size fits anywhere, it's solar compatible and suitable for both indoors and out. Every unit comes fully loaded with memory, built-in amplifiers, a 12 volt power supply and a full set of audio patch cords. Just add a speaker and buttons and it's ready to roll!

Available options include: output speakers, pushbuttons, motion sensors, Podium, handsets, etc.

**MAKING AUDIO EASY...**

**STOP & LISTEN**

DETAILED SPECIFICATIONS ON REVERSE

# Digital Audio Recorder Model DAR-800

## Technical Specifications

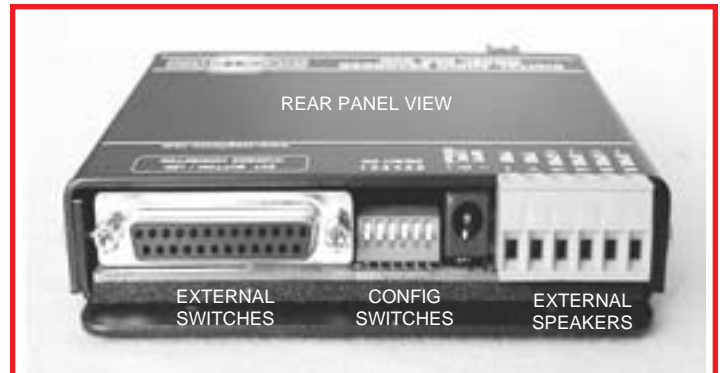
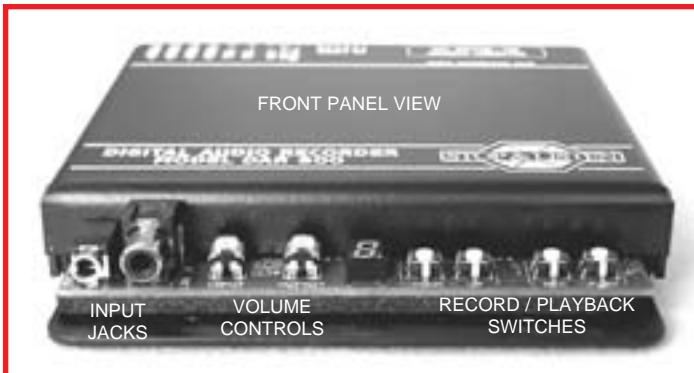

### Specifications: Digital Audio Recorder DAR-800

Digital Sampling Rate is user selectable and effects Frequency Response and Max Recording Time as outlined.

Max. Record Time (per track, min:sec)	1:50	2:45	3:40	5:30
Freq. Resp. (@nom input, +/-3dB)	50-14.5kHz	50-8.2kHz	50-6.2kHz	50-4.1kHz
Digital Compression	none	none	none	2:1 Adaptive
Digital Sampling Rate	39.06kHz	26.04kHz	19.53kHz	26.04kHz

Message Capability	up to 8 messages, accessed one at a time or sequentially
Audio Inputs -Line Level	230mV p-p (-20dBm) sensitivity, 10k impedance, adjustable
-Mic Level	5mV p-p (-53dBm) sensitivity, unbalanced, 30 dB gain, 3.5mm jack
Audio Processing	On-board variable slope compression/expansion
Audio/ Anti-Alias Filters	8th Order Butterworth-type
Dynamic Range	70+dB
Audio Output -Output A	6 watt nom / 2.2 watt true RMS speaker level, bridged, adjustable
-Output B	6 watt as above, user configurable to 200mV Line Level
LED Outputs (8)	5 volt 5mA sourcing, active on playback, dedicated one per message, via DB25 conn.
Memory Type	256mbit / 32MB non-volatile NAND Flash EEPROM
Memory Backup	NOT REQUIRED, non-volatile
A/D Conversion	Companded 8 Bit Linear, real time streaming
Indicators	VU Level on Rec/PB, PowerSaver Status, Play/Record Status, Play Mode, Message ID
Start Inputs	Momentary dry contact closure for single play, sustained for continuous play (Play All) configurable for interruptible or non-interruptible modes
PowerSaver Capability	selectable on/off, proprietary auto-standby mode for remote power systems
Power Consumption	60mA @ 12 VDC (typical, average), 140 microamps standby in PowerSaver mode
Power Supply (supplied)	12 VDC output nominal @ 800 mA, 120 VAC source
Approvals	Class II Device, CSA, UL, FCC CLASS A Compliant
Construction Standard	Industrial/Commercial, carbon steel enclosure, polyester finish
Operating Temp/Humid.	-20°F to +130°F (-30°C to +55°C), non-condensing
Dimensions, Weight	5.0"w x 6.0"d x 0.75"h, 2.0 lbs (130mm x 152mm x 19mm, 0.9 kg)
Warranty	5 year 'Gold Seal' manufacturer direct

*Includes 12VDC Power Supply, Set of Audio Patch Cords, Detailed Operating Instructions*

PRINTED IN CANADA ON RECYCLABLE PAPER

**Stop and Listen**  
**www.stoplisten.com**  
**1-800-387-2365**

DISTRIBUTED BY:

**STOP & LISTEN**

# The SMART AMP<sub>v2</sub>

Automatic Volume Control

## APPLICATIONS

- PA SYSTEMS •
- COMPUTER KIOSKS •
- EXHIBIT HALLS •
- SMALL EXHIBITS •
- MINI-THEATERS •
- TRADE SHOWS •
- VIDEO DISKS •
- ANNOUNCEMENTS •
- CD / LASER DISC / DVD •



Does your audio material get drowned out when you need it most? Too loud when when it should be quiet? The new **SMART Amp** from Stop and Listen is the answer: it's a high fidelity audio amplifier with a *twist!* that's bound to please both staff and visitors.

Using the supplied audio sensor and built-in microprocessors, the **SMART Amp** sweeps the room with soundwaves, 'painting' an acoustic picture of how things should be and storing it in memory. When crowds start building and noise levels rise, the **SMART Amp** automatically adjusts output levels to compensate. The end result is audio that can be heard clearly and evenly, even when Mrs. Smith's 3rd-grade class rolls in after a long bus ride!

When they're gone and things quiet down, volume levels are automatically readjusted back down to more balanced levels. Audio clutter is eliminated and harmony is preserved.

Whether it's a new application or problems with current installations, the **SMART Amp** is the sensible solution where smart volume level control is a necessity! Installation is simple and it comes with a 5 year warranty.

PRINTED IN CANADA ON RECYCLABLE PAPER

**MAKING AUDIO EASY...**

**STOP & LISTEN**

DETAILED SPECIFICATIONS ON REVERSE

# The SMART AMP<sub>v2</sub>

## Technical Specifications

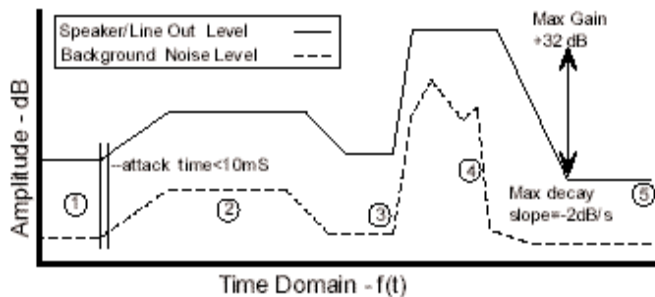
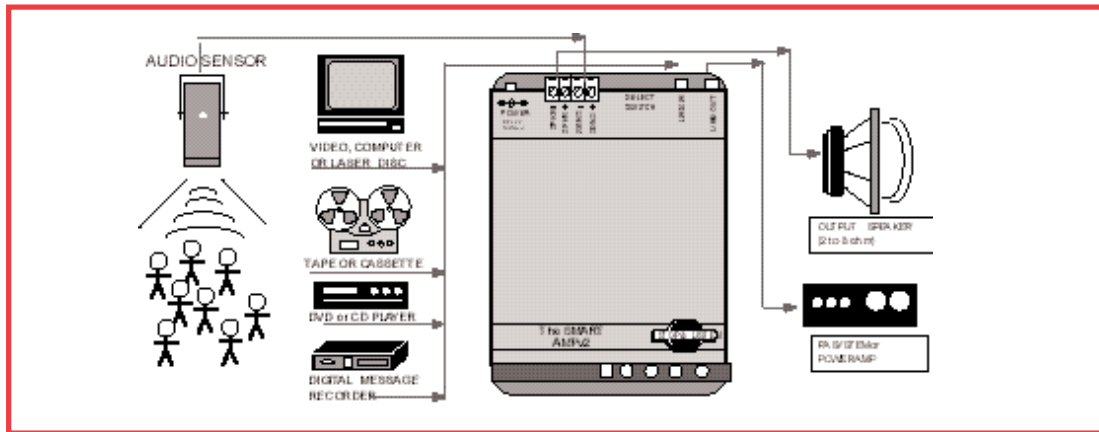

### Here's How It Works

- ① - quiet background noise
- ② - small group detected
- ③ - Mrs. Smith's 3rd Graders!
- ④ - Whew!, there they go
- ⑤ - all's quiet again

## Specifications: The SMART Amp

Monaural 6 watt Hi-Fi Audio Amplifier with auto output attenuation

Frequency Response	20Hz-20kHz +1/-5 dB
S/N Ratio, Dynamic Range	75dB (compressor bypassed), 82dB (compressor enabled)
Audio Input (Line In)	-13dBm to +8dBm(170mV to 2.0V RMS), single ended or differential
User Controls	Input vol., master vol., minimum vol., RUN/TEST mode, sensor sensitivity switchable input compressor, AUTO SETUP mode
Indicators	Input and Sensor VU's, RUN/TEST status, main and sensor POWER status
Audio Sensor	Condenser type, includes line drive amplifier and feedback suppression filters
Acoustic Mapping	full scale sweep response performed during AUTO SETUP routine, 8 bit microprocessor with flash lookup storage, plus self test routines
Audio Output	6 watts @4 ohms, 2 to 8 ohm nominal, overload protected, includes line out
Output Attenuation	-32dB max, adjustable, at both speaker and line outputs
Connections	Line in, line out, speaker out, power and ext. sensor (via 4 pin ejection header)
Output Tracking	10ms attack resp., linear tracking, max 32dB atten., max decay = -2dB/s
Power Consumption	500 mA @12 VDC (typical, average)
Construction Standard	Industrial/Commercial, carbon steel enclosure, polyester powdercoat
Operating Temp	-20°F to +130°F (-30°C to +55°C)
Dimensions, Weight	3.5"w x6.0"d x0.9h, 1.5lb (8.9w x15.2d x2.3h cm, 0.7kg)
Warranty	5 year Gold Seal Warranty

*Includes 12VDC power supply, Audio Sensor w/ mounting hardware, audio patch cords and connectors*

PRINTED IN CANADA ON RECYCLABLE PAPER

**Stop and Listen**  
[www.stoplisten.com](http://www.stoplisten.com)  
**1-800-387-2365**

DISTRIBUTED BY:

**STOP & LISTEN**



# DBA-210 Audio Amp

One/Two Channel Audio Amplifier

## APPLICATIONS

- INFO KIOSKS •
- COMPUTER KIOSKS •
- SMALL EXHIBITS •
- CD PLAYERS •
- DVD PLAYERS •
- VIDEO PLAYERS •
- COMPUTER AUDIO •



Designed for small exhibits and kiosks, the **DBA-210 Audio Amplifier** is a great solution when you need to *pump up your audio* a bit to make sure it gets heard. With 2 separate channels, it's well suited for boosting stereo outputs from PC sound cards, CD players, and DVD videos.

The DBA-210 can even be configured in 'bridged' mode with the flip of a switch, providing up to 12 watts (mono) continuous power when more output is needed.

Solid state construction, rugged design, and superior technology help to make sure this unit is both dependable and economic. Peak reading LEDs and individual volume controls make installation a snap.

Whether it's a new application or problems with current installations, the **DBA-210 Audio Amplifier** is a sensible solution. Each unit comes with a 5 year warranty, audio patchcords, and a 15 volt power supply.

PRINTED IN CANADA ON RECYCLABLE PAPER

**MAKING AUDIO EASY...**

**STOP & LISTEN**

DETAILED SPECIFICATIONS ON REVERSE

# DBA-210 Audio Amplifier

## Technical Specifications

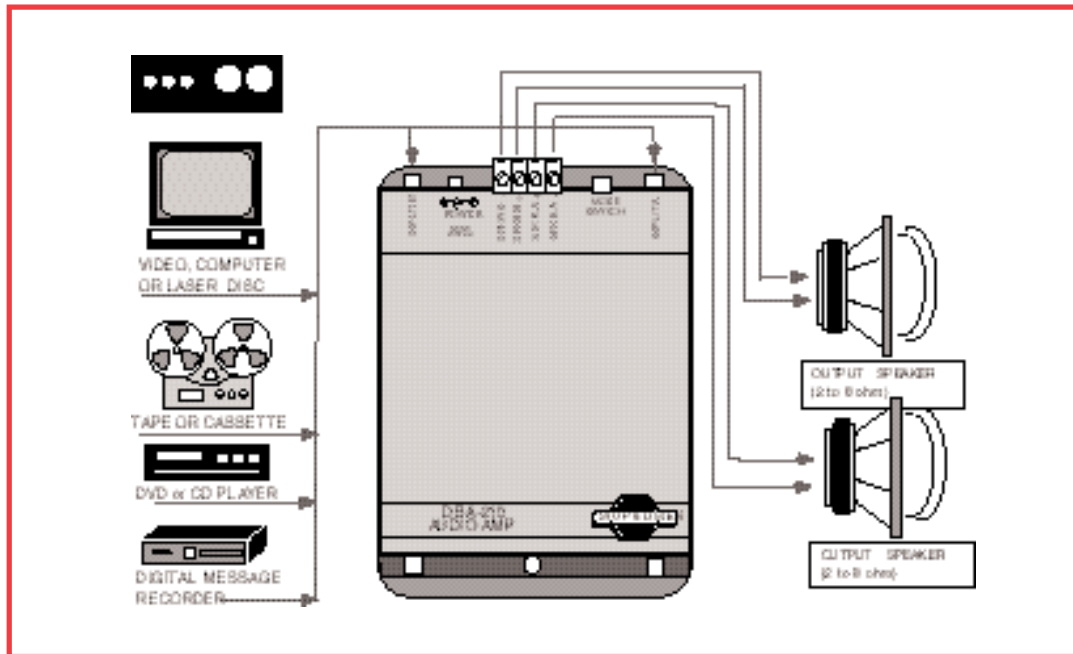

## Specifications: DBA-210 Audio Amplifier

2 Channel 6 watt Bridgeable Utility Audio Amplifier

Frequency Response	20Hz-20kHz +1/-3 dB 8 ohm/channel load
Dynamic Range, s/n Ratio	Greater than 90 dB
Output Power unbridged	6 Watts/Channel @4 Ohms, 3 Watts/Channel @8 Ohms, RMS continuous
Output Power bridged	12 Watts continuous, RMS, 8 ohms, 20 watts Peak
Audio Input (Line In)	-13dBm to +8dBm(170mV to 2.0V RMS), single ended or differential
User Controls	Adjustable Channel Input Attenuation A and B, BRIDGE / DUAL slide switch
Indicators	Channel Input Peak VU / Clip indicators, POWER status
Audio Output -	Ejectable screw header, Short Circuit and Overload protected
Connections	RCA / Phone Line in(x2), speaker outputs (x2), Power
Power Consumption	500 mA @15 VDC (typical, average), 1500mA peak
Construction Standard	Industrial/Commercial, carbon steel enclosure, polyester powdercoat
Operating Temp	-20°F to +130°F (-30°C to +55°C)
Dimensions, Weight	3.5" w x6.0" d x0.9h, 1.5lb (8.9w x15.2d x2.3h cm, 0.7kg)
Warranty	5 year Gold Seal Warranty

*Includes 15VDC power supply, audio patch cords and connectors*

PRINTED IN CANADA ON RECYCLABLE PAPER

**Stop and Listen**  
[www.stoplisten.com](http://www.stoplisten.com)  
**1-800-387-2365**

**STOP & LISTEN**

# GORILLA AUDIO HANDSET

Works with any A/V system

*"It's a Headphone on a Stick"*

- Ideal for:
  - Video Soundtracks
  - Computer Kiosks
  - Trade Shows
  - Museum Exhibits
  - Theaters
- Fulfills ADA Requirements
- Maintenance Free
- Easy To Clean
- Works with Video and Audio Players, DVDs, CD Audio
- Superior Fidelity
- Ant-Theft Security Lanyard
- Simple Installation
- Hearing-Aid Compatible
- Multiple Colors Available



The Gorilla Audio Handset from Stop and Listen is precision engineered to complete virtually any audio or video playback system. In front of a video monitor, at a computer kiosk, or at an audio listening station, it's the perfect choice. It works well with anything with a soundtrack or an audio output.

Multiple handsets? The simple 2-wire interface makes installation easy, even for large theaters and gatherings needing several units. The versatile design can be customized to fit any application.

When regular speakers just can't do the job, the Gorilla Audio Handset from Stop and Listen it gets the message across - plain and simple.

**MAKING AUDIO EASY...**

**STOP & LISTEN**

# The Gorilla Audio Handset

## Technical Specifications

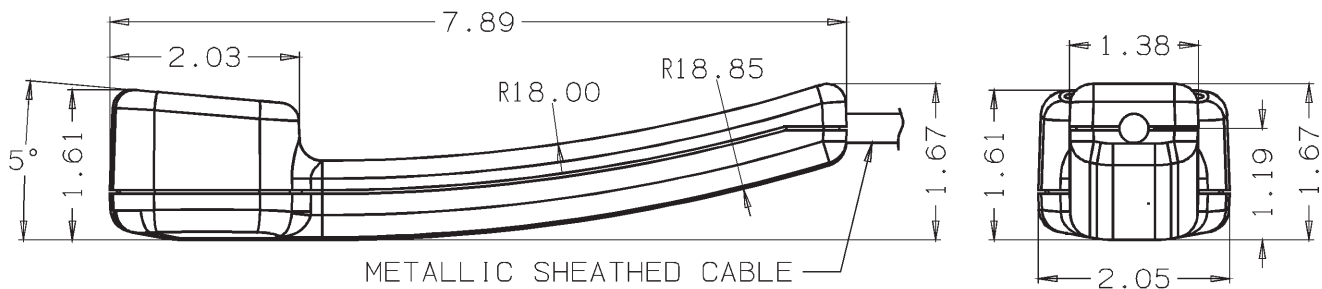
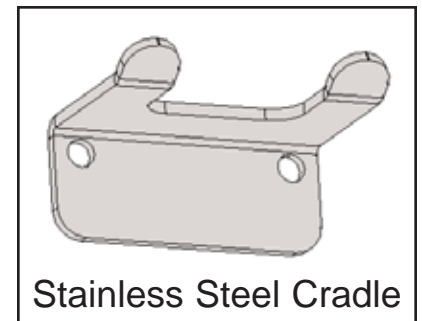
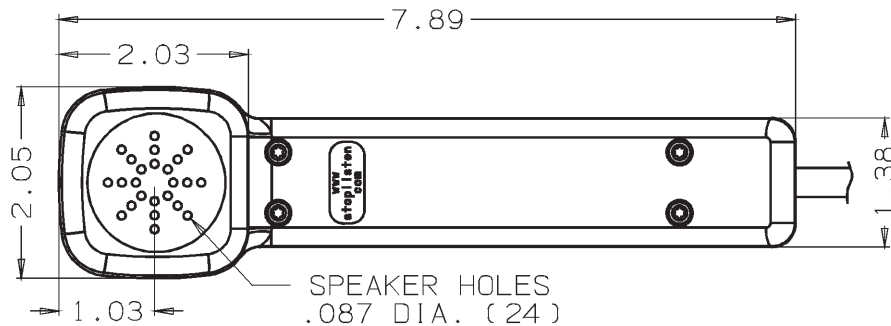

- Lexan PC - PET Alloy Construction
- Full Frequency Response 50Hz - 20KHz
- 32 Ohm Input Impedance
- 30mW Nominal Input Power (Max 70mW)
- 40" square-locked Stainless Steel Cable
- Hygienic and Easy to Clean
- Includes Cradle, Cord Mount, Terminal Block

- Simple Two Wire Connection
- Universal Stainless Steel Cradle
- Mylar Driver Element
- Neodymium Iron Boron (NdFeB) Magnet
- 500 lb. Aircraft Steel Anti-theft Lanyard
- Water Resistant Materials/Construction
- Hearing Aid Compatible / ADA

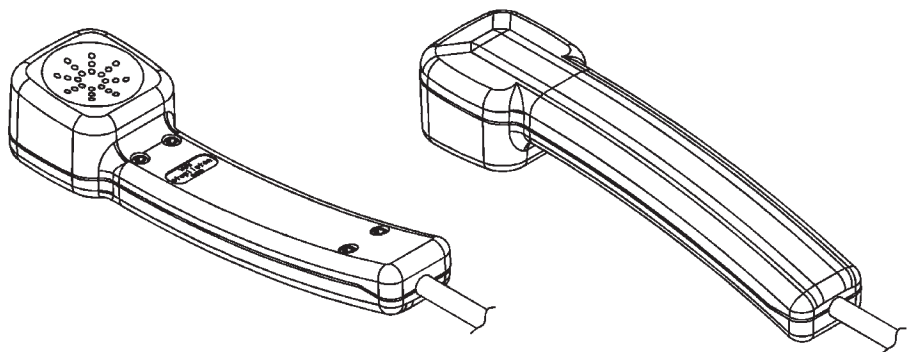

Stop and Listen  
[www.stoplisten.com](http://www.stoplisten.com)  
1-800-387-2365





# Options and Accessories

page 1

The **ARCADE-Style Actuator Button** is always a favorite. Originally designed for the video arcade business, it is readily visible, made from extremely durable nylon, and inexpensive. Stock colors are black, white, blue and red. Special order colors are also available. Button surround is 1.325" dia., plunger is .875" dia, 2-1/2" overall length. Requires 1-1/8" mounting hole, fits materials up to 3/4" thick. Includes crimp connectors. Requires both front and rear panel access.



The **Rectangular Pushbutton** has a black matte finish surround, white background under a clear polycarbonate lens cap. It can be disassembled to install graphics or text under cap. Measures 1.33" by 2.01" (face), 2-7/8" overall length. Requires 1" mounting hole, fits materials up to 3/4" thick. Includes crimp connectors and a 12 volt T1-3/4 incandescent lamp bulb for illumination where required. Also available in round and square configurations or with tinted lens caps by special order.



The **Infra-Red Motion Sensor** can be used to provide an invisible start input to any one of Stop and Listen's Digital Recorders. Very useful for those areas where messages are to be played automatically. These units are field proven and come complete with form 'C' relay contacts and electrical connectors. The 'viewing' area can be easily adjusted by simply masking off the front window to suit virtually any pattern.



Can't find it here? Contact Stop and Listen: we'll help you find what you're looking for.

**MAKING AUDIO EASY...**

**STOP & LISTEN**

THERE'S MORE ON THE OTHER SIDE

# Options and Accessories

page 2

The **5.5" All-Weather Flush Mount Speaker** uses polypropylene construction for lasting performance under tough conditions. Well suited for built-in applications, both indoors and out. Co-axial woofer/tweeter, 35 watts continuous power, 4ohm impedance, 35-25kHz dynamic response. Rear panel mount, requires 5.0" dia. mounting hole, fits materials up to 3/4" thick. Includes tamper resistant steel grill, audio cable, mounting hardware. 1 yr warranty, 2-1/2 lb shipping weight.



The **BSI - 90 Monitor Speaker** is a 2-way bass reflex speaker with a cast aluminum back-box and perforated steel grill. Well suited to surface mount and/or bookshelf-type indoor applications. 3-1/2" woofer, 2" soft dome tweeter, 20 watts continuous power, 8 impedance, 60-20kHz dynamic response. Measures 7-1/4"(w) x 4-1/2"(d) x 4-1/2"(h), matte black finish. 1 yr warranty, 7 lb shipping weight. Includes swivel mounting bracket, various mounting hardware, standard quick-connect terminals.



The '**Gorilla**' **Audio Handset** is great for applications where messages and soundtracks shouldn't be overheard by passers-by. It features injection-molded lexan alloy construction, a 40" armored stainless steel cable, and a 1000 lb. test steel lanyard inside the cable to prevent abuse. Includes stainless steel cradle, lanyard mounting bracket, and connection hardware. Measures approx. 8.5"(h) x 3.25"(d) x 2"(w). 90 day warranty, shipping weight 2 lbs.



PRINTED IN CANADA ON RECYCLABLE PAPER

Can't find it here? Contact Stop and Listen: we'll help you find what you're looking for.

**Stop and Listen**  
[www.stoplisten.com](http://www.stoplisten.com)  
**1-800-387-2365**

DISTRIBUTED BY:

**STOP & LISTEN**

# Options and Accessories

page 3

**10 Watt Solar Power Package** - sized for use with individual message recorders. (10 watts peak output at 12VDC). Includes Solarex MSX-10 semi-crystalline panel or equiv, 33A•Hr gelled 12 volt storage cell, photovoltaic regulator, cabling, connectors. Panel dimension: 16-1/2"(w) x 10-5/8"(h) x 7/8"(d). Aluminum framed. Universal mounting rails provided on panel. Typical storage cell is 7-1/2"(w) x 6-1/2"(h) x 5-1/24"(d), 24 lbs, may require drop shipping due to transport restrictions.



**30 Watt Solar Power Package** - sized for use with multiple message recorder units (30 watts peak output at 12VDC). Includes Solarex MSX-30 semi-crystalline panel or equiv., universal mounting bracket, 33A•Hr gelled 12 volt storage cell, photovoltaic regulator, cabling, connectors and fasteners. Panel dimension: 23-1/2"(w) x 18-12"(h) x 2"(d), aluminum framed. Typical storage cell is 7-1/2"(w) x 6-1/2"(h) x 5-1/24"(d), 24 lbs, may require drop shipping due to transport restrictions.

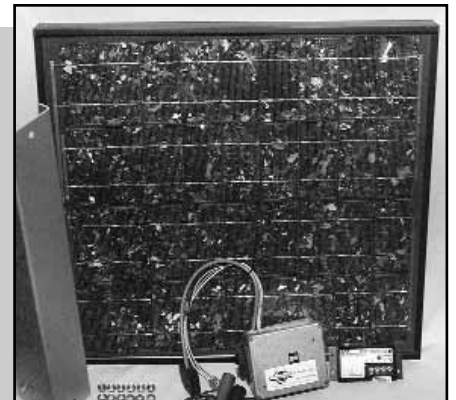

**Full Support Web-Site** - Stop and Listen Inc maintains a complete web-based product and customer support site on a CGI server with JAVA applet support. Find the answers to commonly asked questions, download the most recent versions of technical literature and instructions, look through the archives for older materials or simply browse through the products and new products areas to find the latest in exhibit audio products. You can also find e-mail links direct to technical support.

**www  
stopleften  
com**

[info@stopleften.com](mailto:info@stopleften.com)

Can't find it here? Contact Stop and Listen: we'll help you find what you're looking for.

**MAKING AUDIO EASY...**

**STOP & LISTEN**

THERES MORE ON THE OTHER SIDE

# Options and Accessories

page 4

Ask about **Battery and Remote Power Packages** for your application. Stop and Listen Message Recorders use advanced PowerSaver technology. Many remote installations can be powered by batteries alone, saving substantial time and money. PowerSaver circuitry puts the recorder into an ultra-low power 'sleep' mode when it's not in use. When a button is pushed, the unit 'wakes up' and gets right to work. Remote power packages can be engineered on a site-by-site basis by our technical staff.



The **DBA-210 Utility Amplifier** is a great solution when you need to *pump up* your audio to make sure it gets heard. With 2 separate channels, it's well suited for boosting stereo outputs from CDs, DVD videos, etc. for kiosks and small exhibits. Switch to 'bridged/mono' mode and get up to 12 watts where more power is needed. 20-20kHz dynamic range, low noise, solid-state construction. Measures 3-1/2"(w) x 6"(d) x 1"(h), matte black finish. 5 yr warranty, 1 lb shipping weight. Includes power supply, patch cords, clip indicators and individual volume controls.



**Quality Electrons** - Stop and Listen employs only top-grade, high-quality electrons in every one of our products. All electrons used by Stop and Listen must meet minimum electromagnetic and physical guidelines as follows: charge =  $(4.80294 \pm 0.00008) \times 10^{-10}$  absolute electrostatic units (AEU), dia =  $(1 \pm 1.99978) \times 10^{-10}$  cm, rest mass =  $(0.9109534 \pm 0.33528) \times 10^{-30}$  kg, with a magnetic moment of no greater than, and no lesser than,  $(9.284832 \pm 23.5554673) \times 10^{-24}$  J/T.

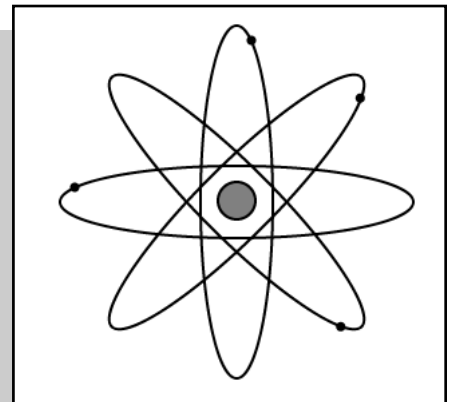

Can't find it here? Contact Stop and Listen: we'll help you find what you're looking for.

Stop and Listen  
[www.stoplisten.com](http://www.stoplisten.com)  
1-800-387-2365

DISTRIBUTED BY:







**50 States, 10 Provinces, 25 Countries, and 6 Continents**  
**here's just a few of the places you'll find audio from Stop and Listen:**

RijksMuseum (National Museum, Amsterdam, The Netherlands)  
Iqaluit Visitors Centre (Resolute Bay, Baffin Island)  
Createl S.A. (Brussels, Belgium)  
U.S. Department of Defense - US Army (Bonn, Germany))  
Unicorn International Productions (Tokyo, Japan)  
Museo de Ciencia y Parque Ecologico (Mexico City, Mexico)  
WindInfo South Africa (Durban, South Africa)  
Denver Museum of Natural History (Denver, CO)  
Metro Toronto Zoo (Toronto, ON)  
Westinghouse Hanford Facility (Richland, WA)  
Dawson City Museum (Dawson City, YK)  
Museumder (De Hooze Veluwe National Park, Holland)  
Canadian Museum of Civilization (Hull, PQ)  
Lopez Guerra (Leon, Mexico)  
Mansveld Integrated Media Projects BV (Eindhoven, Kingdom of the Netherlands)  
Western Arctic Regional Visitor's Centre (Inuvik, NWT)  
Gulf Islands National Seashore, National Park Service (Gulf Breeze, FL)  
John G. Shedd Aquarium (Chicago, IL)  
Pico International H.K (Shatin N.T., Hong Kong)  
Impulse Radio Holdings (Christchurch, New Zealand)  
Fundacion Tiempos Nuevos (Santiago, Chile)  
Alexander Graham Bell National Historic Site (Baddeck, NS)  
Loyola Medical Center - Children's Burn Unit (Chicago, IL)  
Audubon Institute (New Orleans, LA)  
National Center for Atmospheric Research (Boulder, CO)  
Johnson Space Center (Dallas, TX)  
Busch Creative (St. Louis, MO)  
Nat'l Research Council - Dominion Radio Astrophysical Observ. (Penticton, BC)  
US Army Core of Engineers (Paola, KS)  
Inuit Heritage Center, Hamlet of Baker Lake (Baker Lake, NWT)  
New Mexico Museum of Natural History (Albuquerque, NM))  
The Smithsonian Institute (Washington, DC)  
The National Zoo (Washington, DC)  
Kuwait Science Center (Kuwait City, Kuwait)  
Goddard Planetarium (Roswell, NM)  
Montreal BioDome (Montreal, PQ)  
Alaska Whale Foundation/Biological Sciences (Simon Fraser University, BC)  
Dubovis Deseno (Buenos Aires, Argentina)  
Intermarket Agencies (Kowloon, Hong Kong)  
Brooklyn Children's Museum (Brooklyn, NY)  
Banff National Park (AB)  
AT&T Bell Labs (Murray Hill, NJ)  
CXC Software Engineering (Shatin NT, Hong Kong)  
London Regional Children's Museum (London, ON)  
Harbor Branch Oceanographic Institute (Fort Pierce, FL)  
Los Alamos National Labs, Bradbury Science Center (Los Alamos, NM)  
MIT Massachusetts Institute of Technology Museum (Cambridge, MA)  
Beijing Chinese Museum Products Company (Beijing, Peoples Republic of China)  
Fox Studios / Studio de le Playa (Rosarito, Mexico)  
Digistar Holdings SDN BHD (Ampang Utama Selangor, Malaysia)

.....etc., etc., etc.

**Stop and Listen Inc**

7515 Flint Road S.E., Calgary, Alberta, Canada T2H 1G3

www.stopliscen.com 1-800-387-2365 voice 403 276-5905 fax 403 230-9243 e-mail info@stopliscen.com

# STOP and LISTEN Inc COMMERCIAL PRICE LIST

**\$USD**

EFFECTIVE MAY 01, 2016

## PRODUCT DESCRIPTION

refer to product cutsheets for detailed specifications

## LIST

<b>DIGITAL AUDIO RECORDER Model DAR-050</b> _____ (superior fidelity, 1message, 110 sec. capacity, 5 yr warranty, on-site recordable)	\$385
<b>DIGITAL AUDIO RECORDER Model DAR-100</b> _____ (superior fidelity, 1message, 11 minutes capacity, 5 yr warranty, on-site recordable)	\$680
<b>DIGITAL AUDIO RECORDER Model DAR-200</b> _____ (superior fidelity, 1or 2 messages, 22 mins capacity, 5 yr warranty, on-site recordable)	\$820
<b>DIGITAL AUDIO RECORDER Model DAR-800</b> _____ (superior fidelity, 8 messages, 44 mins capacity, 5 yr warranty, on-site recordable)	\$960
<b>SMART AMPv2 AUDIO AMPLIFIER</b> (incl. Audio Sensor) _____ (8 Watt Hi-Fi mono line amplifier w/ auto-output attenuation)	\$315
<b>DBA-210 UTILITY AMPLIFIER</b> _____ (2 channel / bridgeable 10 watt audio amplifier)	\$185
<b>ARCADE STYLE PUSH BUTTON</b> _____ (industry standard, stock colors incl: black, white, red, blue)	\$6
<b>RECTANGULAR PUSH BUTTON</b> _____ (clear w/white background w/black surround, removable cap for graphics insertion)	\$6
<b>5-1/2" ALL WEATHER FLUSH-MOUNT SPEAKER</b> _____ (premium quality, w/steel grill and mounting hardware, 5" mounting cut-out req'd)	\$60
<b>BSI-90 MONITOR SPEAKER</b> _____ (w/ universal mounting bracket and hardware, diecast enclosure, compact size)	\$60
<b>GORILLA AUDIO HANDSET</b> _____ (50-20kHz, Lexan Alloy w/ 40" stainless steel cord, mounting hardware)	\$85
<b>INFRA-RED MOTION SENSOR</b> _____ (Form 'C' dry contacts, suitable for indoor applications)	\$55
<b>10 WATT SOLAR PACKAGE</b> For DAR-050, 100, 200, 800 _____ (incl. 10W solar array, ASC 12/1 solid-state regulator, storage cell, wiring, hardware)	\$390

Can't find it here?  
Give us a call: Stop and Listen has access to hundreds of  
additional products to complete all your exhibit needs

**1-800-387-2365**  
**www.stoplisten.com**

All prices in \$USD, shipping, duty and brokerage not included.



printed in Canada on recyclable paper